



Joseph in Prison

Genesis 39:1-2, 20-23; Genesis 40:5-14

Level B

Ages 7-10

Life Focus: The Lord is always with me.

Memory Verse: The Lord was with Joseph and whatever he did the Lord made it prosper. Genesis 39:23

Story Summary: Joseph's brothers put him in a pit and later he was sold to passing traders. He was taken to Egypt where he was sold as a slave. Proving trustworthy, he was soon put in charge of his master Potiphar's household. One day Potiphar's wife falsely accused Joseph of improper behavior, and he was thrown in prison. The prison keeper came to trust him and put him in sole charge of the other prisoners. Pharaoh's butler and baker were imprisoned and while under Joseph's care they told him their dreams. Joseph explained the dreams, saying that the Lord revealed their meaning. The butler would serve Pharaoh again, but the baker would die. The dreams came true as Joseph predicted.

Lesson 2

Materials you need

		Supplied with Lesson	Additional Materials
1. Getting Started (2-3 min)	Welcome Warm-up Activity	Welcome Warm-up Activity directions p. 20	
2. Focus on the Word Use all activities (5-7 min)	Read the Word Talk About It story discussion	Talk About It discussion guide p. 20 Teaching Pictures pp. 23-24	Bible or copy of Genesis 39:1-2, 20-23; 40:5-14
3. Learn by Doing Choose 1-2 activities (15-20 min)	Make a hanging create a hanging depicting the dreams of Pharaoh's butler and baker	Butler and Baker Dream Hanging directions p. 21 <i>Butler and Baker Dreams Hanging</i> pp. 25-27	scissors, crayons, markers or colored pencils, sticks or dowel rods 12-15 in (30-40 cm) long, string or yarn cut in lengths of 18 in (45 cm) (2 per child), string or yarn cut in 12 in (30 cm) lengths (1 per child), tape
	Make a paper whirl an interactive project creating the illusion of Joseph in prison	Joseph in Prison Spinning Disc directions p. 21 <i>Spinning Disc</i> p. 28	crayons, markers or colored pencils, scissors, tape, piece of string approx. 48 in (120 cm) in length
	Make a 3-layer picture see the Lord's presence with Joseph in prison	Joseph in Prison Lift and Reveal Picture directions p. 22 <i>Joseph in Prison</i> pp. 29-30	scissors, crayons or markers, glue, stapler
	Picture to Color	Joseph Interprets the Butler & Baker's Dreams p. 31	crayons, markers or colored pencils
4. Wrap It Up (2-3 min)	Memory Verse introduce <i>Memory Verse</i> for the week	Memory Verse <i>Parent Note</i> p. 32	

1. Getting Started

Welcome Warm-up Activity

Simon Says

Start a game of “Simon Says” by saying “Simon says do this” and then do an action you want the children to copy. Encourage listening by occasionally asking the children to do an action *without* saying Simon says. The children should *not* copy these statements! If children have been sitting before class, start with active movements, e.g. “Simon says put your hands in the air!” or “Simon says touch your toes!” Switch to quieter actions, e.g. “Simon says sit down” as you prepare to teach.

2. Focus on the Word

Read

Genesis 39:1-2, 20-23; 40:5-14

Show the **teaching pictures** on pp. 23-24 as you discuss the story.

Talk

Optional: grapes, goblet, basket with bread in it

About It

Joseph’s brothers hated him and put him in a pit. He was taken out and sold to passing traders. The traders took him to a new country that was far away—Egypt.

Joseph worked for a man named Potiphar. Joseph was faithful and honest and Potiphar trusted him and put him in charge of his household. Then Potiphar’s wife told her husband lies about Joseph. Potiphar believed his wife and put Joseph in prison. How do you think Joseph felt?

Has anyone ever said or thought that you have done something that you did not do? What was it like?

The Lord was with Joseph even when he was in prison. What job did the keeper of the prison give him? Joseph was put in charge of all the other prisoners.

One day Pharaoh, the king of Egypt, put two of his servants in prison. Who were they? The butler and the baker. The butler would have served Pharaoh drinks such as wine. The chief baker made bread.

Why did they talk to Joseph? They had dreams that they could not understand.

What did the butler dream? He saw a vine with three branches that blossomed and produced grapes. He squeezed the grapes into Pharaoh’s cup and gave it to Pharaoh. *Optional:* show grapes and a goblet as you review the dream.

What did the dream mean? The butler would be taken from prison and serve Pharaoh again.

What happened in the baker’s dream? There were three baskets on his head. The top basket had bread in it. Birds came and ate the bread. *Note:* The Heavenly Doctrine tells us that the baskets had holes in them so that the bread could fall through. *Optional:* show a basket with bread.

What did the dream mean? Within three days Pharaoh would put the baker to death.

What did Joseph ask the butler to do? Remember him to Pharaoh.

Did he do it? He forgot.

Even though Joseph seemed forgotten in prison, the Lord was with him in his heart. And so the Lord blessed everything Joseph did. The Lord is with you too—even if you are feeling alone. The Word says, “Yea, though I walk through the valley of the shadow of death, I will fear no evil; for You are with me” (Psalm 23:4). He is always with us and can more easily teach and bless us if we carry Him in our hearts and minds.

3. Learn by Doing

Choose one or two activities



Butler and Baker Dream Hanging

Create a hanging (mobile) depicting the dreams of the butler and baker.

1. Hand out the *Butler and Baker Dreams Hanging* pages (pp. 25-27), crayons, markers or colored pencils, and scissors.
2. Fold the page with the shaded half-bird shapes in half lengthwise. Cut around the birds on the folds and unfold for whole birds. Color birds on the unshaded side of the paper (see photo). Color the baker's head, the hand squeezing grapes, the cup filled with juice, and the drops of grape juice.
3. Cut out around each piece.
4. Give each child a stick and 2 longer pieces of string or yarn. Help children tie one end of each string to each end of the stick.
5. Stretch the string out straight. Tape the cup to the end of one piece of string. Tape the three drops of juice to the string above the cup. Tape the hand with the grapes above the drops.
6. Tape the baker's head to the end of the second piece of string, and the two birds above the baker's head.
7. Give each child a shorter piece of string. Tie the ends to the center of the stick as a hanger. The mobile will balance more easily if both ends of the string are tied to the stick as shown in the photograph. Slide strings along the stick until the mobile balances.



Materials for each child

Butler and Baker Dreams Hanging pp. 25-27; crayons, markers or colored pencils, scissors, straight stick or dowel rod about 12-15 in (30-40 cm) long, 2 pieces of string or yarn at least 18 in (45 cm) long, 1 piece of string or yarn about 12 in (30 cm) long, tape

Prepare in Advance

Make a sample hanging to use as a demonstration model.



Joseph in Prison Spinning Disc

Mount pictures of Joseph and prison bars back-to-back on a looped string. Whirl them around and pull to create the illusion of Joseph being in prison.

1. Give each child 1 copy of the disc on p. 28, crayons, scissors, string and tape.
2. Color the picture of Joseph. Cut out the circles with Joseph and the prison bars.
3. Cut a out a disc of cardboard the same size as the pictures.
4. Tape the prison bars to one side of the cardboard.
5. Tie ends of the string together to form a loop. Form the loop into a figure 8 with the knot at the center of the figure 8. Use the guidelines to position the string horizontally on the prison picture and tape down.
6. Tape the picture of Joseph to the other side of the cardboard disc. Tape the edges.
7. Holding one end of the string in each hand, "wind up" the center disc by holding one hand still while turning the other like a jump rope. Once the string is wound up, pull firmly on both ends so the disc spins. Look for the illusion that Joseph is "in" prison.

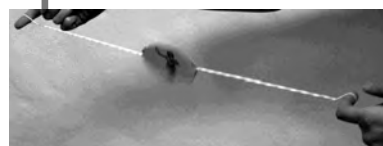

Materials for each child

1/2 of the *Spinning Disc* p. 28 printed on regular paper; cardboard (e.g. cereal box) cut to the size of the pictures (important for weighting the disc), crayons or markers, scissors, string or yarn 48 in (120 cm)

Note: yarn does not work as well as string.

Choice

Joseph in Prison Lift and Reveal Picture

Lift the layers to see that the Lord was in Joseph's heart while he was in prison.

1. Give each child a copy of pp. 29-30, crayons or markers, scissors and glue.
2. Color the pictures of Joseph and the Lord in Joseph's heart.
3. Cut along all the dotted lines on both pages.
4. Cut away the white spaces between the prison bars.
5. Put glue on the bottom of each of the three prison bars and lay the piece of paper with the words "in prison" across the bottom of the bars. Allow to dry.
6. Arrange the 3 pages as layers in the following order: prison bars, Joseph, Lord in Joseph's heart. Staple at the top.
6. Lift the page with Joseph, to see the Lord with him in the prison.
7. Joseph kept trusting in the Lord and doing what was right even when he was put in prison. He was soon put in charge and was able to help other prisoners, like the butler and baker.

**Materials for each child**

set of *Joseph in Prison* pages (pp. 29-30), crayons or markers, scissors, glue, stapler

Choice

Picture to Color: Joseph Interprets the Butler & Baker's Dreams

Hand out copies of the picture and invite the children to color it.

Materials

picture p. 31, crayons, markers, or colored pencils

4. Wrap It Up

Memory Verse

The Lord was with Joseph and whatever he did the Lord made it prosper.
Genesis 39:23

Read the *Memory Verse* aloud. Repeat it slowly several times. Invite the children to say it with you. Say "The Lord was with Joseph." Ask the children to repeat it with you. Say "and whatever he did the Lord made it prosper." Ask the children to repeat it with you. Say the whole sentence and have children repeat it with you.

Closing

The Lord was with Joseph and He is with each of us too! No matter what happens to us the Lord is taking care of us all the time. When we feel sad or lonely, we can invite the Lord to help us by remembering things He says in His Word. You could think about the Lord's prayer, a mealtime blessing or a recitation you have learned. This week remember to bring the Lord's words into your mind!

Hand each child his or her projects and a *Parent Note* (p. 32) to take home.





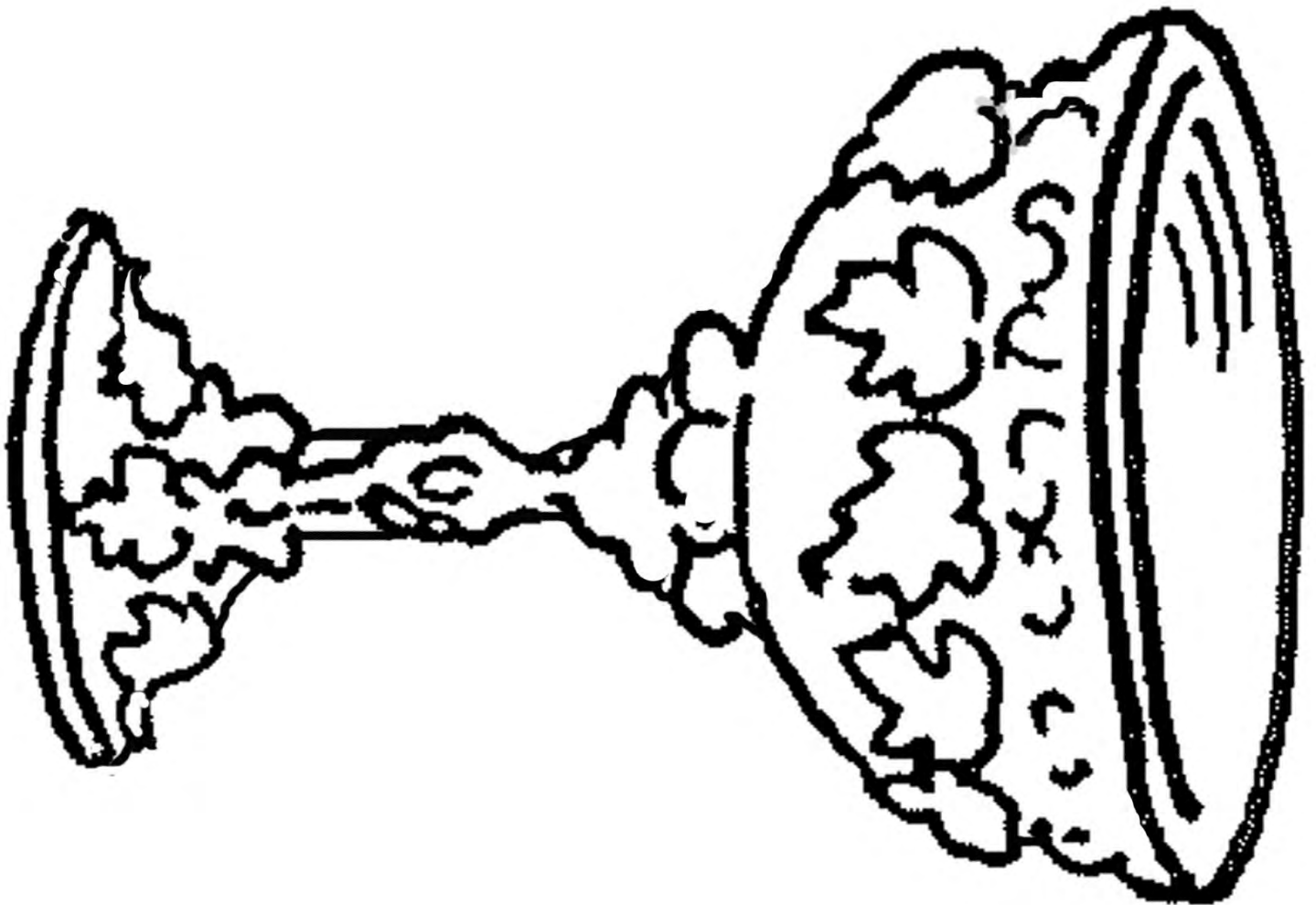
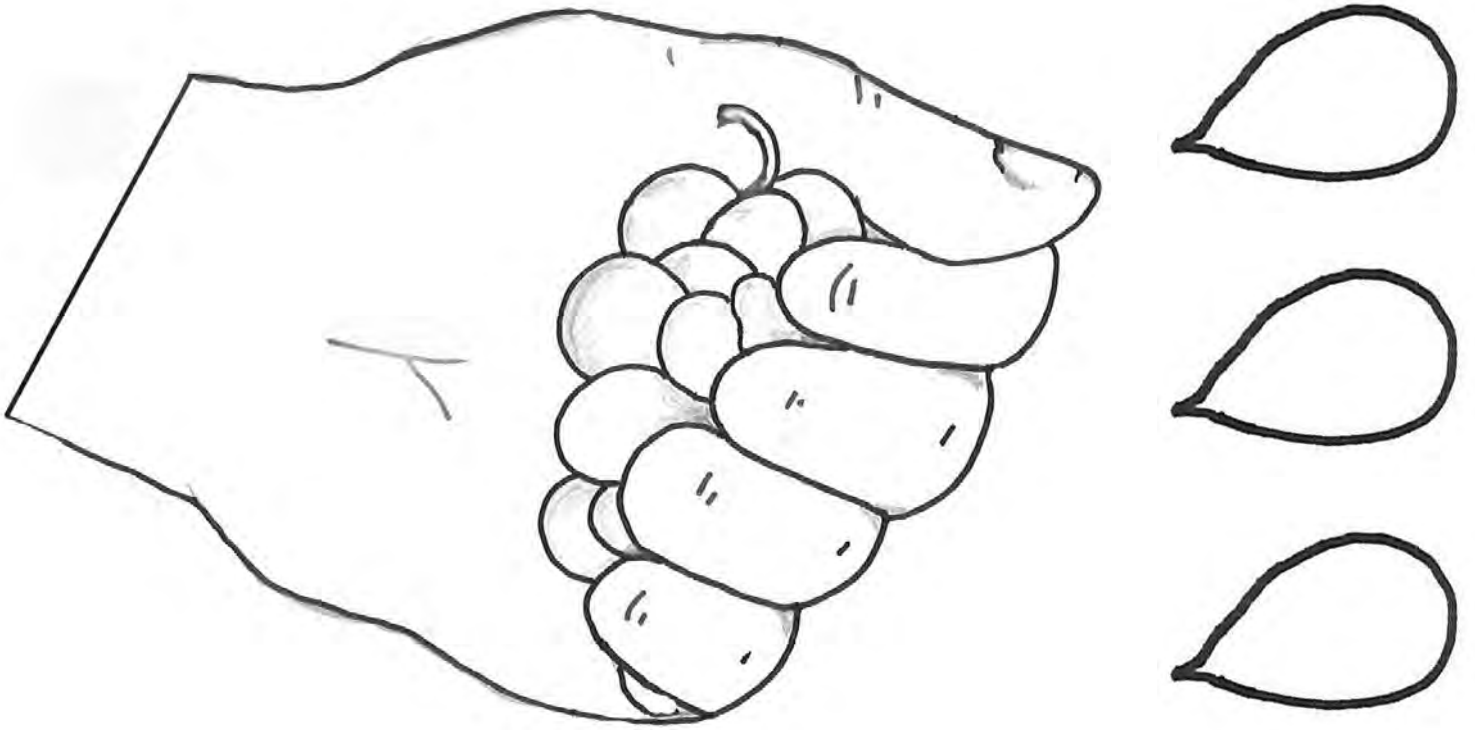

Butler and Baker Dreams Hanging

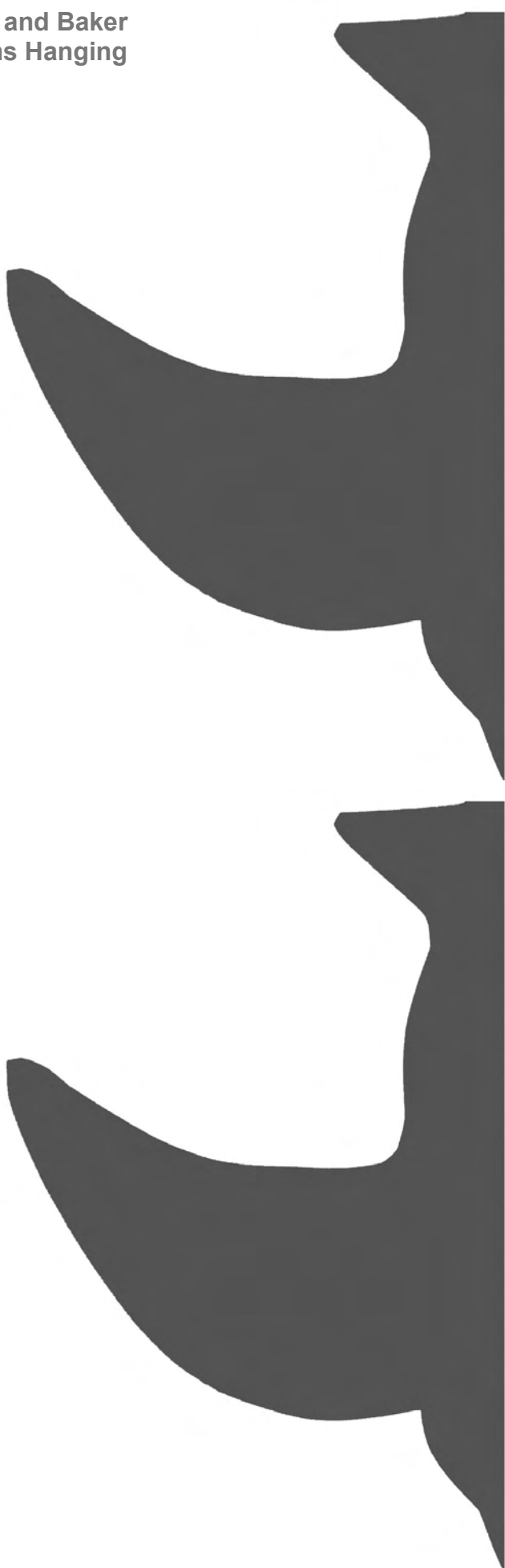

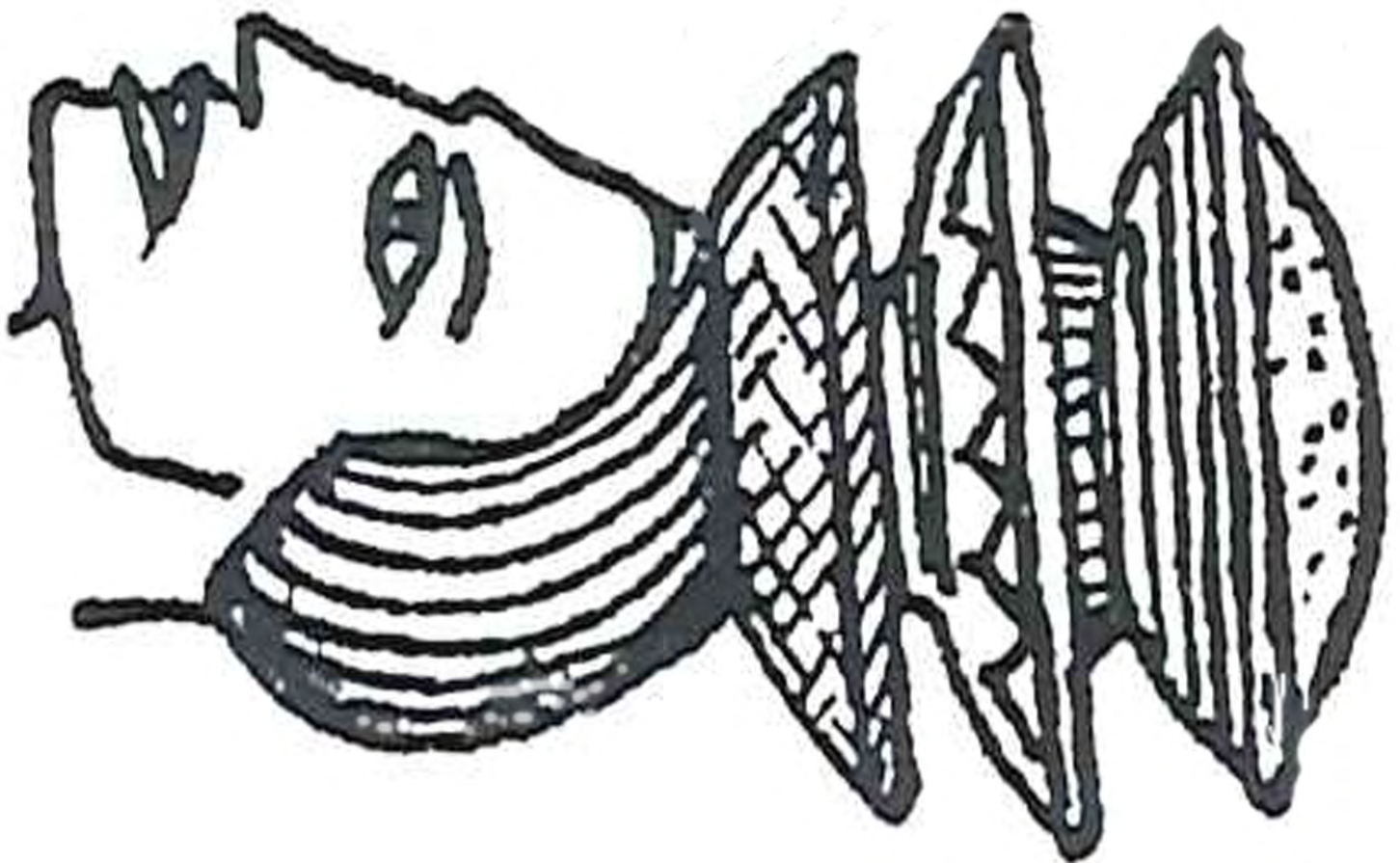
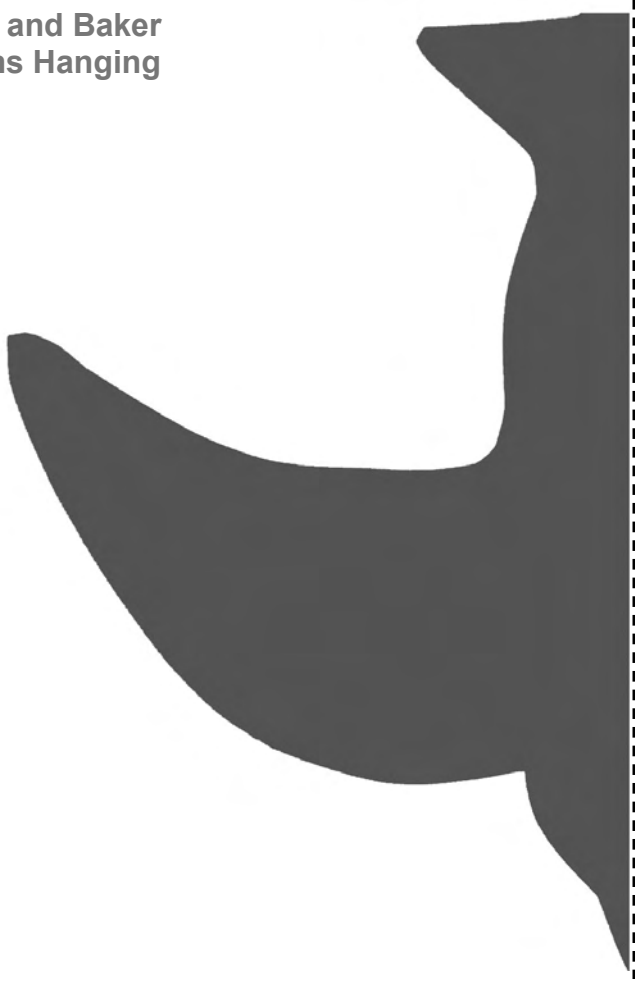

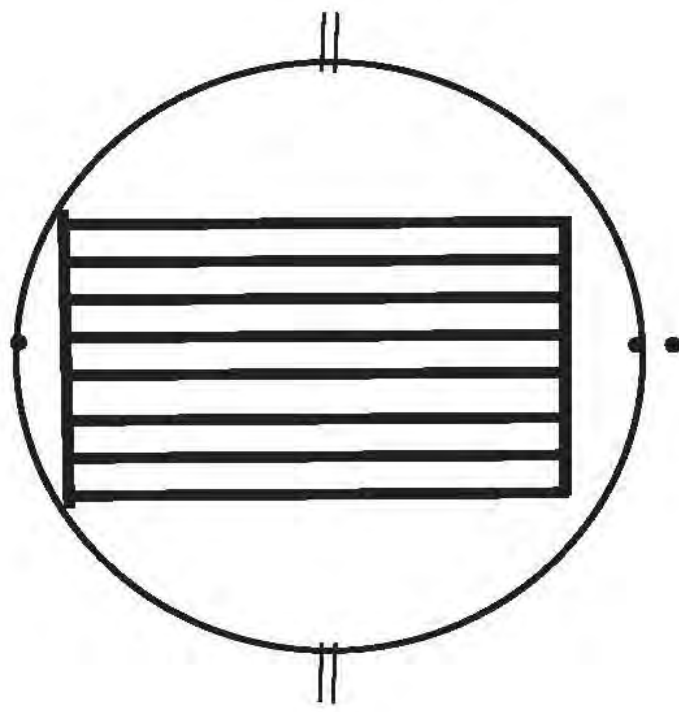
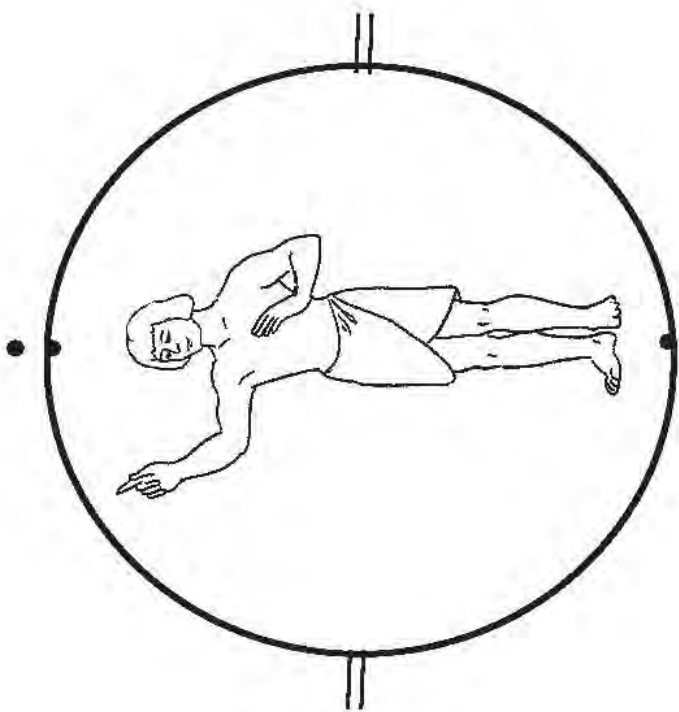
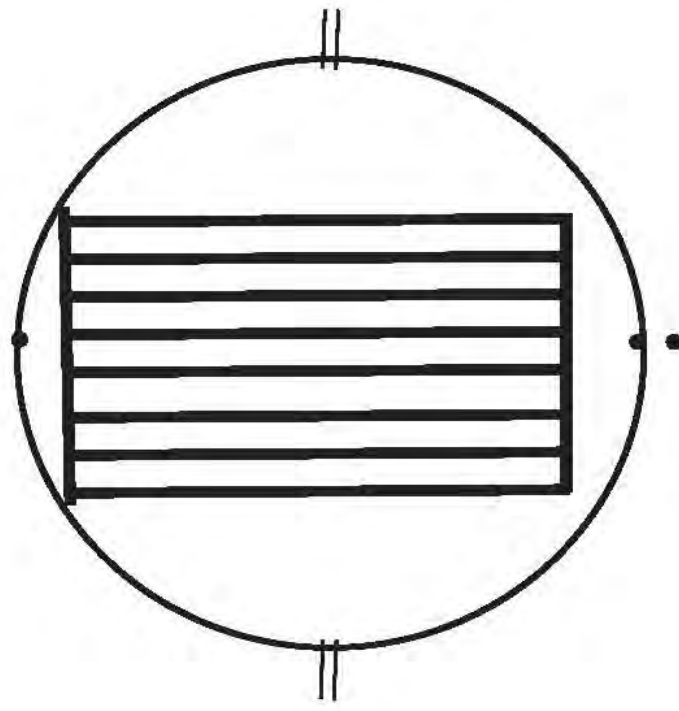
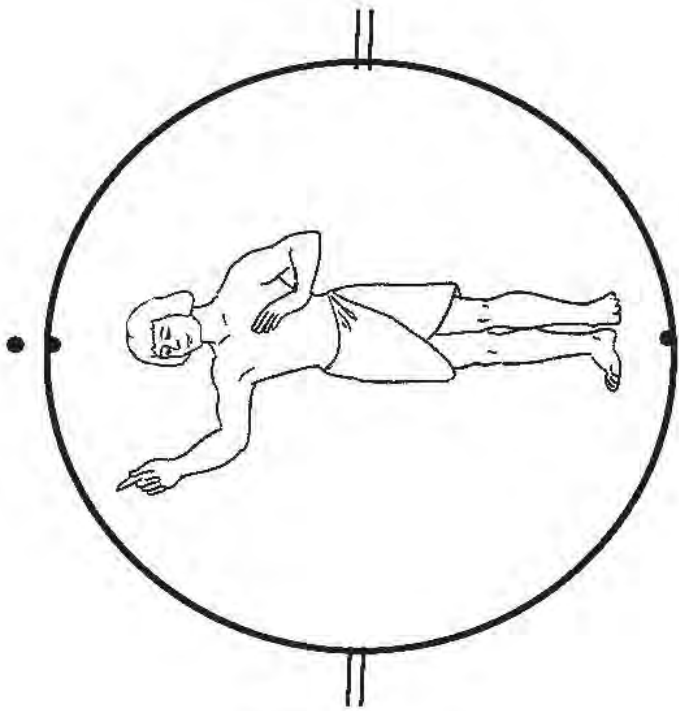

Spinning Disc

Joseph

in prison

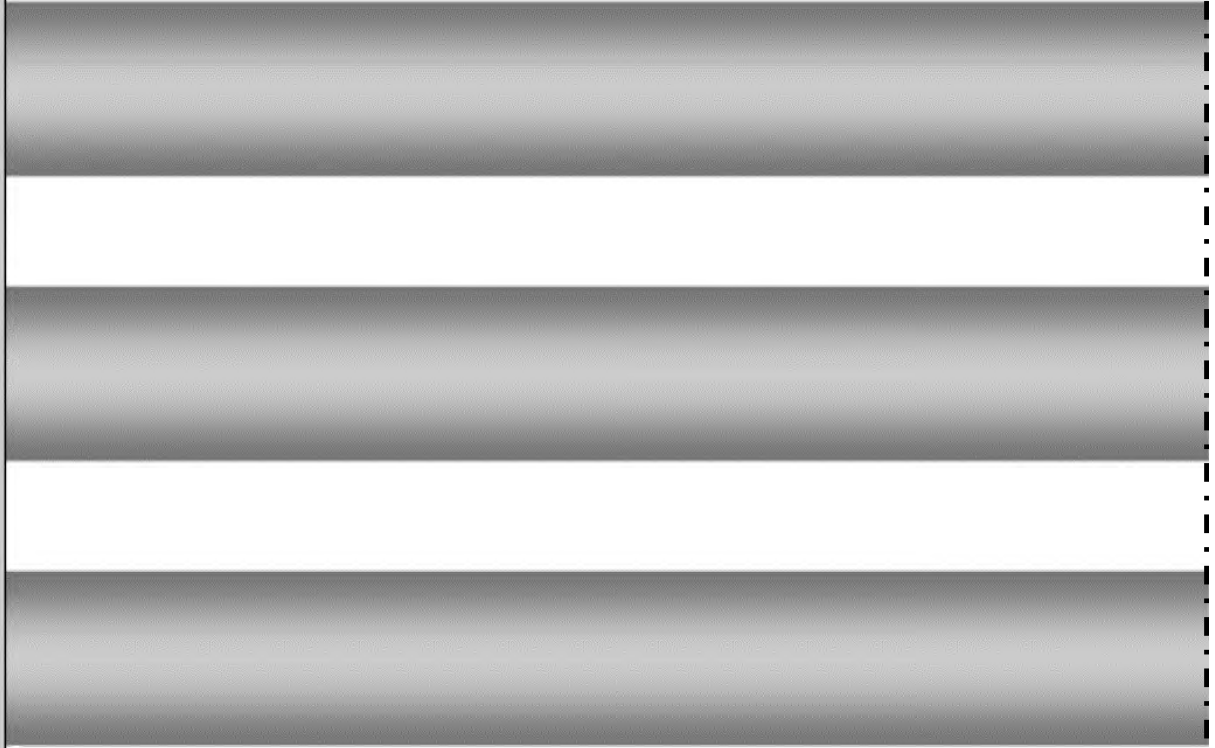

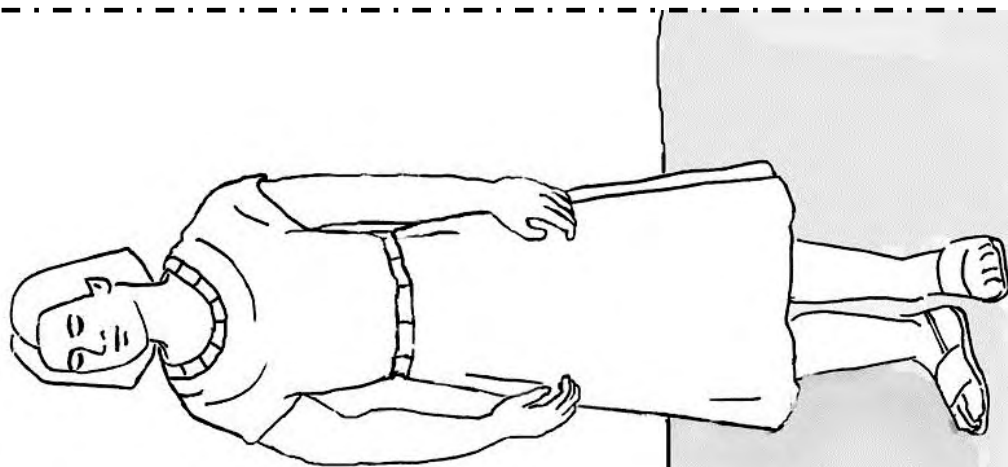

Joseph in Prison

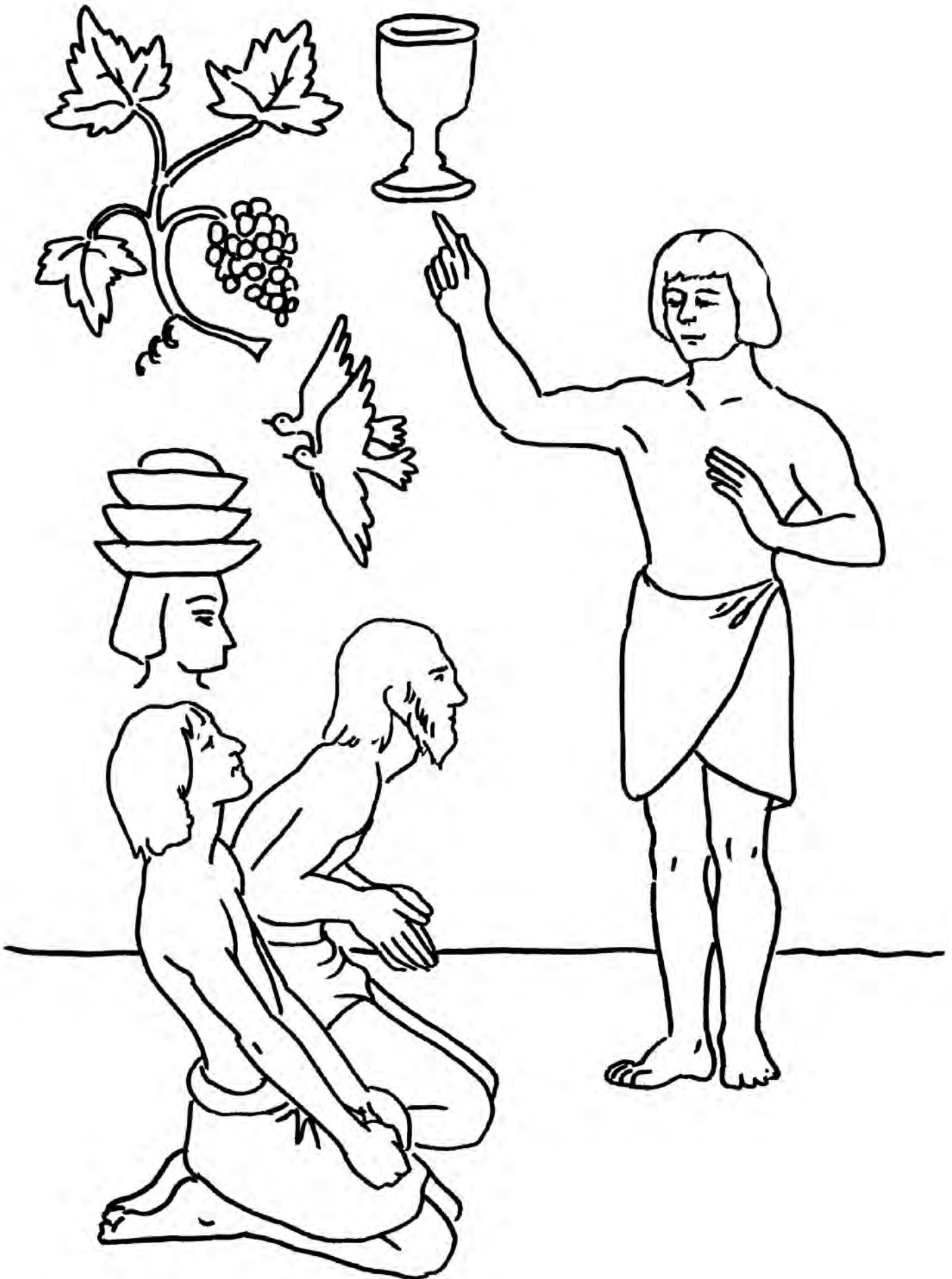

Parent Notes

Make a copy for each child. Hand out as children leave.

<p style="text-align: center;">PARENT NOTE</p> <p>Dear Parents,</p> <p>Today’s lesson focused on the story of Joseph’s imprisonment (Genesis 39:1-2, 20-23; Genesis 40:5-14). Please ask your child about the butler and the baker’s dreams! We encourage you to help your child keep the Lord’s Word in his or her heart by learning this week’s Memory Verse. Try saying it once or twice in the morning, at mealtime or before bed!</p> <p style="text-align: center;">Memory Verse</p> <p>The Lord was with Joseph and whatever he did the Lord made it prosper. Genesis 39:23</p>	<p style="text-align: center;">PARENT NOTE</p> <p>Dear Parents,</p> <p>Today’s lesson focused on the story of Joseph’s imprisonment (Genesis 39:1-2, 20-23; Genesis 40:5-14). Please ask your child about the butler and the baker’s dreams! We encourage you to help your child keep the Lord’s Word in his or her heart by learning this week’s Memory Verse. Try saying it once or twice in the morning, at mealtime or before bed!</p> <p style="text-align: center;">Memory Verse</p> <p>The Lord was with Joseph and whatever he did the Lord made it prosper. Genesis 39:23</p>
<p style="text-align: center;">PARENT NOTE</p> <p>Dear Parents,</p> <p>Today’s lesson focused on the story of Joseph’s imprisonment (Genesis 39:1-2, 20-23; Genesis 40:5-14). Please ask your child about the butler and the baker’s dreams! We encourage you to help your child keep the Lord’s Word in his or her heart by learning this week’s Memory Verse. Try saying it once or twice in the morning, at mealtime or before bed!</p> <p style="text-align: center;">Memory Verse</p> <p>The Lord was with Joseph and whatever he did the Lord made it prosper. Genesis 39:23</p>	<p style="text-align: center;">PARENT NOTE</p> <p>Dear Parents,</p> <p>Today’s lesson focused on the story of Joseph’s imprisonment (Genesis 39:1-2, 20-23; Genesis 40:5-14). Please ask your child about the butler and the baker’s dreams! We encourage you to help your child keep the Lord’s Word in his or her heart by learning this week’s Memory Verse. Try saying it once or twice in the morning, at mealtime or before bed!</p> <p style="text-align: center;">Memory Verse</p> <p>The Lord was with Joseph and whatever he did the Lord made it prosper. Genesis 39:23</p>